

SCARY TERRY'S HALLOWEEN PAGES

<http://www.scary-terry.com/vortex/vt.htm>



Update Halloween 2007....

The "rotating tunnel that you walk through"* just completed its fourth Halloween season and I've got to say it's getting better with age. The wooden hoops are "wearing-in" to conform nicely to the bicycle guide wheels and it runs very smoothly and quietly. This is by far the highlight of my haunt. The kids keep circling the house just to walk through the tunnel. This Halloween, a total of 1206 people passed through the tunnel (How do I know this? I'd like to say it's some sophisticated counting device, but alas, one rainy day I sat down and watched the video at 2x speed and counted everyone going through).

*update 8/2008: This tunnel was formerly called another name (starting with V and ending with x) but I've been informed that it's a trade name and that I can no longer use it.

Following are some construction details and pictures of the final setup.

I'd like to give thanks to several people for their help and inspiration:

- Professor Time and Spirit Kanaka have web sites with very helpful information.
- My friend Jim, without who's help this project would not be possible.
- My family, who put up with my insanity

Obtained from
Omarshauntedtrail.com



The heart and soul of any "rotating tunnel that you walk through" is the tunnel itself. This one will be comprised of three 10' diameter "hoops" attached together.



These hoops start as a drawing on a computer. Each hoop will be made of 16 pieces, with each piece being 1/8 of the arc. The pieces are overlapped (double thickness) for joining together.



The individual pieces are cut from 1/2" plywood using a CNC router (thanks Jim). The accuracy of this device is absolutely amazing. If you're interested in getting your own set of hoops made, you can [contact Jim](#). I think he charges about \$250-\$300 plus shipping for a set of three hoops.



Here are the individual arcs for one hoop ready for assembly



and being put together.

Obtained from
Omarshauntedtrail.com



The joints fit together perfectly to form the complete circle. Note that I'm now using "T" nuts instead of loose nuts as shown in the above picture.



When the three hoops are joined together, they'll rest on three pairs of bicycle wheels. Of those six wheels, five are free spinning (like the one shown right) and the sixth is driven by a motor which rotates the overall tunnel.



This is the drive wheel/motor mechanism. Now you may be asking yourself "why is it so complicated?" The answer is because I'm cheap. I had a high quality, 2HP, 3450 RPM motor sitting around and didn't want to spend money on a slower motor. I had to devise a way to slow that motor speed down to the

approximately 5 RPM the tunnel needs. This is what I came up with. The final tunnel speed was 5.5 rpm which seemed to be perfect.



Here is the bridge that will go through the middle of the spinning tunnel.

As seen here, it's about 80% complete. It is 20' long overall (two 10' sections joined together) and made of 2x10 lumber as the primary structure.

It has been tested with over 400 pounds in the middle and deflection was less than 1/4" (whew!).

Obtained from
Omarshauntedtrail.com



The final version of the bridge was a little different than these pictures show. The walking surface of the bridge was moved up to the middle of the side 2x10's which allowed us to run 2x4 bracing underneath to strengthen the hand rails. The final version is a **very** solid structure.



Here are a couple more pictures of the tunnel under construction.

Just for size reference, the white thing on the left side of the picture is a full sized refrigerator. In the background is the CNC router that created the rings.



Obtained from
Omarshauntedtrail.com



Here are some pictures of the initial setup. It's really hard to take pictures of since it's so large.

I find the canopy is essential to protect the tunnel from weather and to keep out stray light.

This is a 10x20 canopy with leg extensions to raise it an additional three feet to accommodate the tunnel.



When completed, it's entirely enclosed on the sides and ends. More pictures of our 2007 setup can be found [here](#).



One of the problems of using wooden hoops is protecting them from the weather.

If they get wet, there's always the potential of warpage and swelling.

The first year we set it up, we had a couple days of rain before we could finish.

The hoops actually swelled up enough that they wedged themselves in the bicycle wheels.

Obtained from
Omarshauntedtrail.com



A handheld router with a rabbeting bit solved the problem by trimming the hoops to better fit the wheels. An added benefit was smoother running wheels. They are now fully painted with latex paint to help resist moisture.



Here is Jim and his son Jay attaching the cloth lining to the tunnel. You can see the cloth is pretty thin, but that's what you get for \$1.49/yard. At night, it worked very well.



At right is my wife painting dots and lines on the lining.

Obtained from
Omarshauntedtrail.com

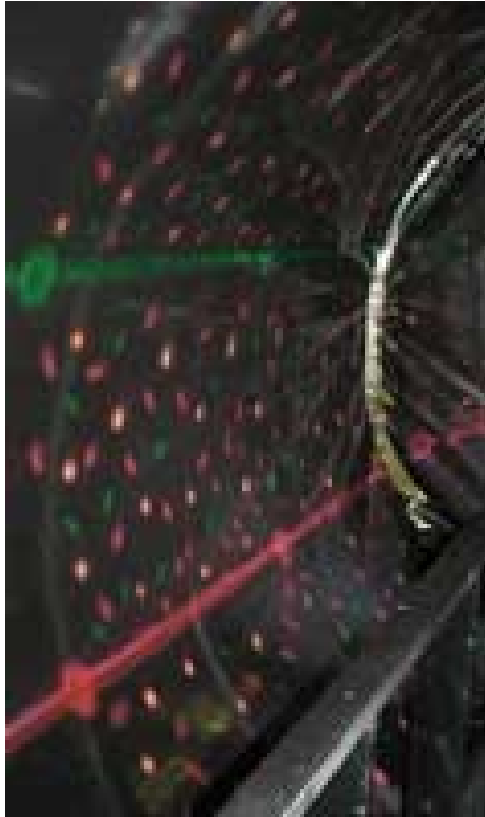

At first, we really weren't sure what kind of pattern to paint on the inside of the tunnel.

I couldn't find much info on the web about what works the best, so we decided to paint a spiral pattern.

It didn't work well. There was very little sensation of spinning, mainly because the lines, being more vertical, showed very little visual movement.

We blacked out the spiral (you can see the remnants of it in the right picture) and painted lines and dots. WHAT A DIFFERENCE!

The effect went from mild (spiral) to overwhelming (dots and lines).

If you're planning on making a tunnel, I strongly recommend a pattern that will give the greatest sense of movement.

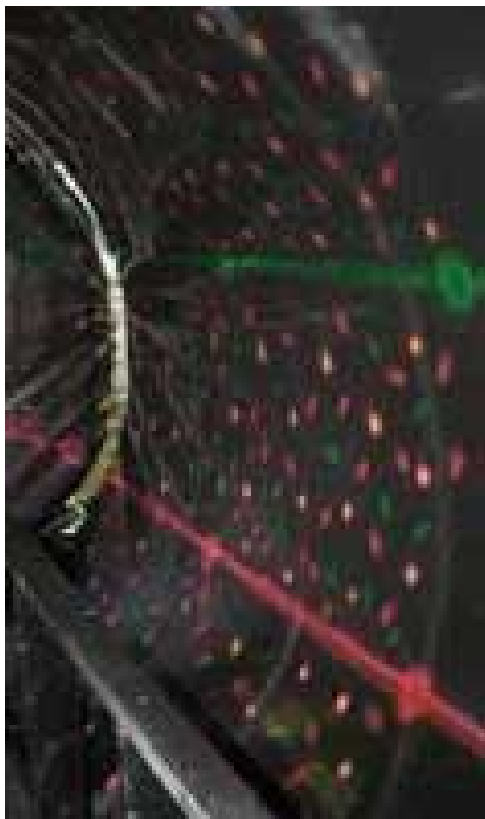

Another piece of advice I can offer is that you need to eliminate all outside references. Any reference to outside stationary objects or light will considerably diminish the effect of the tunnel.

Since our tunnel is in the back yard, it's nearly impossible to completely control the sunlight without building a hard wall structure.

Because of this, the effect of the tunnel is not nearly as good during the day as it is at night.

Obtained from
Omarshauntedtrail.com



These are the stairs for the bridge. The handrails were made from arcs leftover from our test hoop.



Here's a sign Jim made on the CNC router. (The red paint "runs" were intentional.)



This is the completed tunnel. Believe me, the picture doesn't do it justice. Standing on the bridge, with the tunnel rotating around you is an incredible feeling.

Obtained from
Omarshauntedtrail.com

Side view of bridge

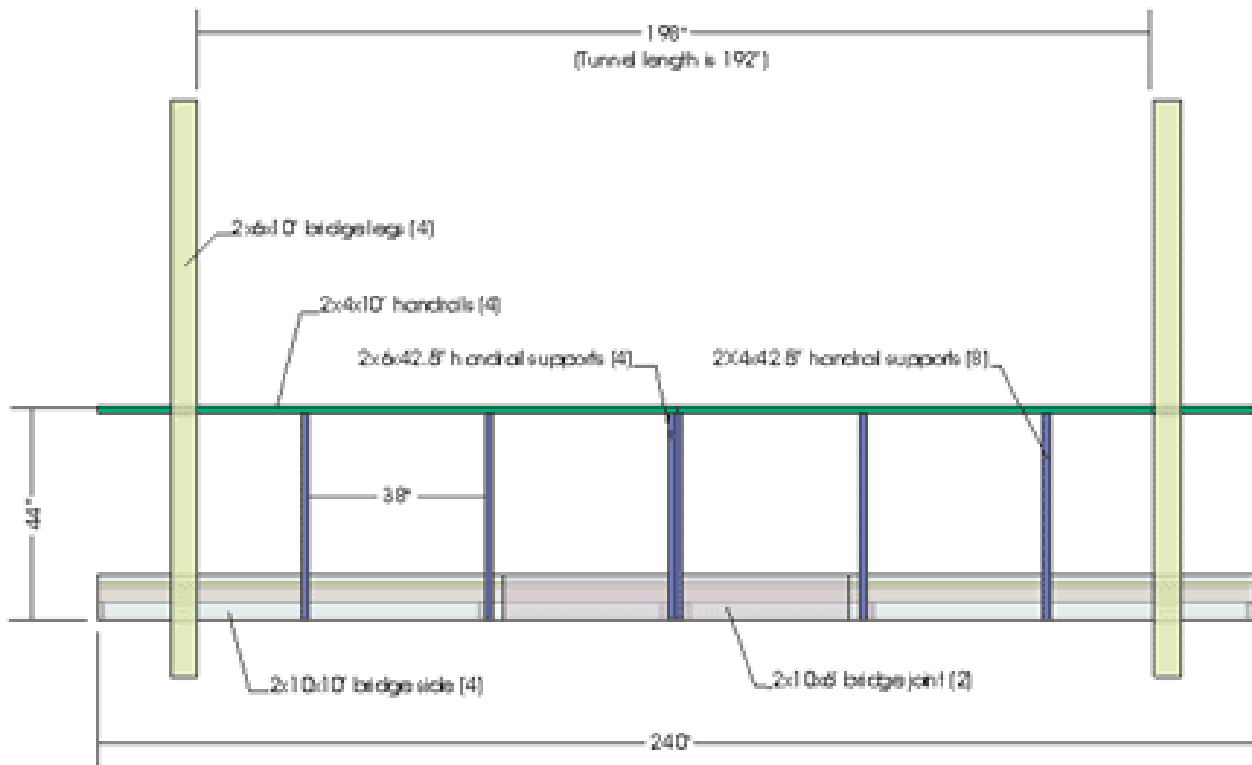

End view of bridge/tunnel

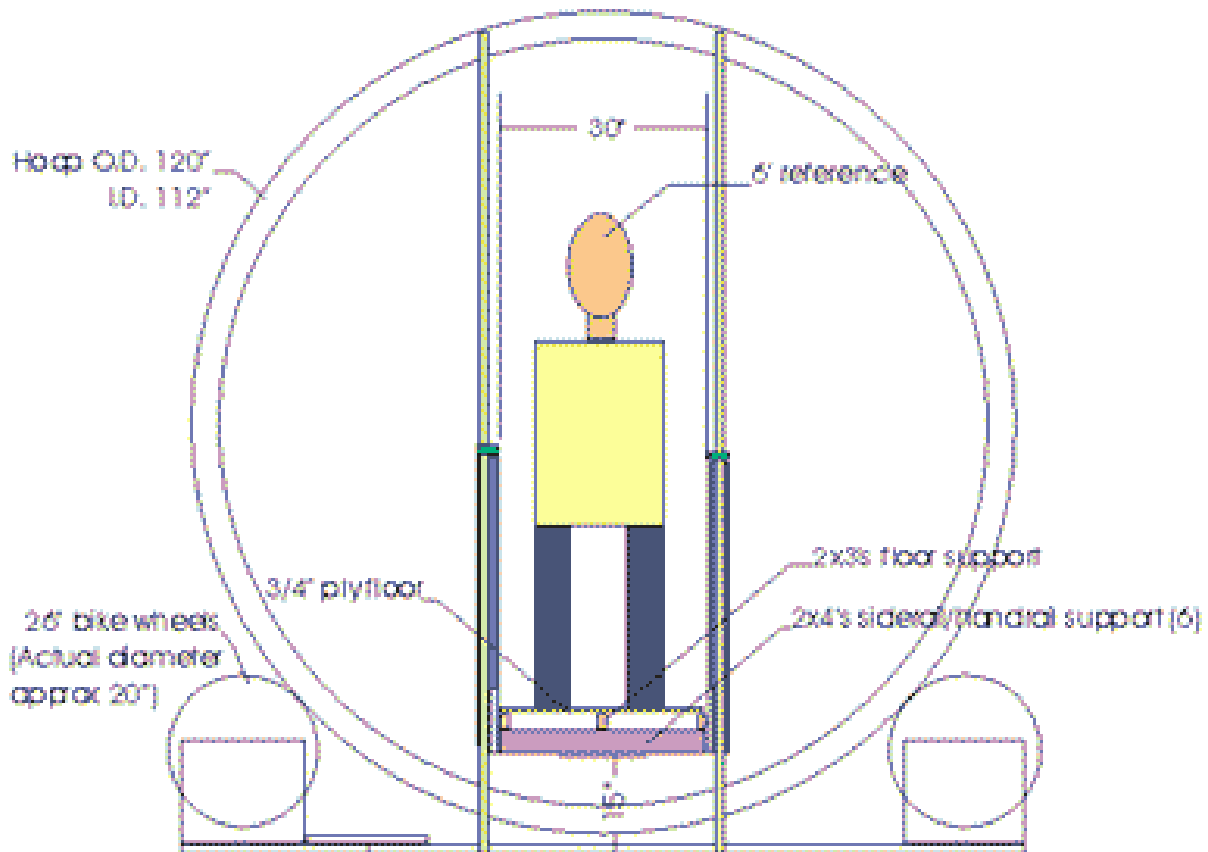

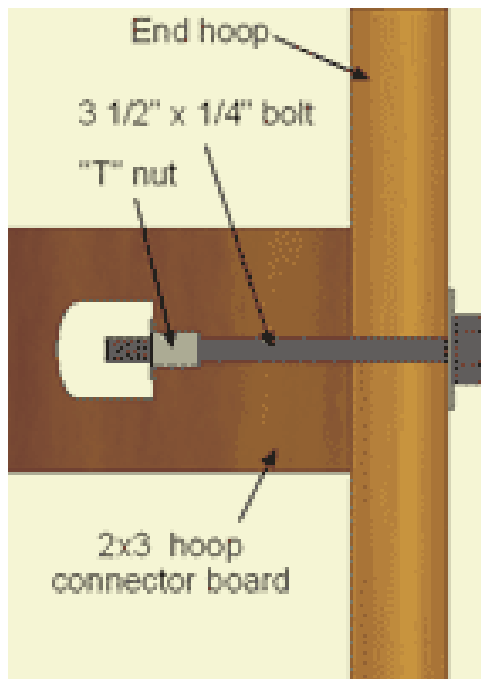

The hoops are connected together using 8' long 2x3's.

There are eight of them between each pair of hoops for a total of 16. These drawings show how they're connected

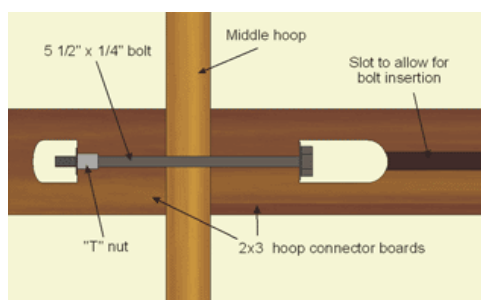

Halloween 2007



Here are some pictures of the "rotating tunnel that you walk through" setup which took place on Oct. 20th. I'd like to give a sincere thanks to many CalHauntS members who took time away from their own haunts to come out and help. It was much appreciated!!!!!!

Obtained from
Omarshauntedtrail.com



Obtained from
Omarshauntedtrail.com

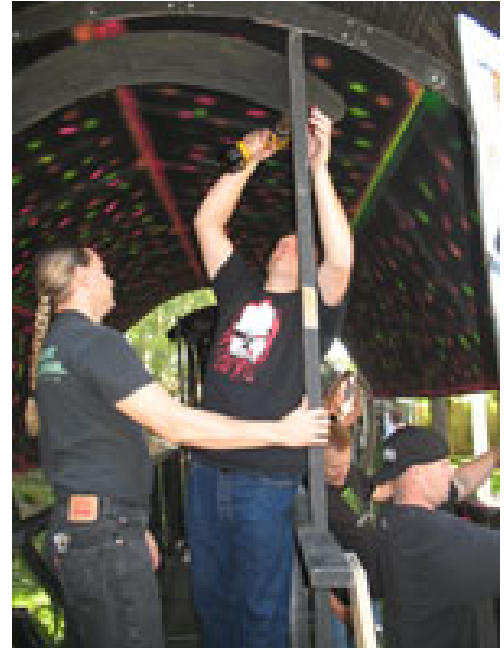

"rotating tunnel that you walk through" FAQ's

- Q: Why did you change the name from Vortex Tunnel to "rotating tunnel that you walk through"?

A: I got this request asking me to change the name because "Vortex" is a "trade" name. Many people thought I should fight back, since this type of tunnel has been called a vortex tunnel for many years, but it really wasn't that important to

me what my tunnel was called. I did some checking on-line through the US Patent and Trademark Office and it appears that "Vortex Tunnel" is not an officially reregistered trade mark.

- Q: What kind of fabric do you use as a lining?

A: When it came time to purchase the fabric lining, we'd already spent way too much on the tunnel construction and I didn't want to spend another \$300 on fabric, so my wife purchased the cheapest black fabric we could find from the fabric store. I don't know what it's called, but it was less than \$2 a yard and is pretty thin. By luck, the fabric width turned out to be EXACTLY perfect for running between the horizontal ring supports. The downside of such cheap fabric is that it doesn't block light well so the tunnel must be enclosed to eliminate outside references. The upside to the fabric is that it's very light weight and has held up pretty well to usage over the last several years.

- Q: How do you attach the fabric to the rotating tunnel?

A: We use staples. It's pretty time consuming and a hassle and it tends to rip the fabric a bit, but it's inexpensive and works ok. I've always wanted to develop a system of snaps for attachment of the fabric to the tunnel but haven't done it yet.

- Q: What do you use to paint the dots and lines on the fabric?

A: We use Krylon florescent spray paint from the local hardware store. It takes two or three coats to make the colors stand out, but it's very quick and easy to apply, works well with black light and the effect is outstanding.

- Q: How do you shoot the video in the tunnel?

A: The tunnel is lit with black lights (UV) and most cameras, be it still or video, will not work with UV at all. The trick was to add lighting that a camera would respond to without spoiling the effect. The answer was to use a camera sensitive to IR lighting and supplement the tunnel with IR lights. Many people have reported they've had good luck with the inexpensive security cameras that Harbor Freight sells, so I picked up both a color and black and white version when they were on sale. I think I paid less than \$50 for both of them. A test of the two cameras showed virtually no difference under IR lighting, I think I chose to go with the black and white camera, but I recall it was a toss-up between the two. It's important to note that the IR lights that come with these cameras are completely useless if you're trying to shoot more than a couple of feet from the camera. I did

some experimenting and ended up adding about 90 IR LEDs mounted above the exit to the tunnel.

- Q: What kind of IR LEDs did you use to illuminate the tunnel for the video?

A: There are two types of IR LEDs commonly available, 850nm and 940nm. What's the difference between the two? The human eye can detect light in the 380-750nm range. Since the 850nm LED is fairly close to this range, you can see a faint red glow from the LED, where the 940nm LED appears completely dark. I would have preferred to have gone with the 940nm LED, but in tests with the Harbor Freight camera, it just didn't produce enough light so I opted for the 850nm LED. They do give off the red glow but it's not too distracting in the tunnel. I purchased my IR LEDs from [BG Micro](#).

- Q: My tunnel will be indoors and I don't have room for the 10' diameter rings, can I use a smaller size?

A: I know of a haunter (Spirit Kanaka) that uses 9' diameter rings with success. My concern is that anything smaller will be too close to your patrons and it's too easy to reach out and touch the tunnel walls which can cause lots of problems. 10' works great and I'll stick with that.

- Q: How well do your wooden rings hold up?

A: My wooden rings, which are made up of 1/2" overlapping plywood, are very fragile individually, but when attached together, are very strong and work well. Through years of usage, they've "worn in" and seem to be getting better with age. However, I live in Southern California where it's dry most of the time. The rings have gotten a little damp before and have swollen up a bit. I would not recommend the wooden rings in a wet, high humidity climate unless they are well protected.

- Q: Can I purchase a template for the spinning tunnel hoops?

A: I don't have a template for the hoops. My friend Jim, who designed the hoop sections, may have something to offer, you can contact him for information. The hoop sections are not too hard to duplicate. If you look at [this picture](#), each one of the sections is 1/8th of a 10' outside diameter circle. The sections are 4" wide and made from 1/2" plywood. The hole spacing allows them to be overlapped and allows for cross members, which connect the rings together, to be attached

- Q: Aloha Terry, I lead a hands on science program, Earl's Garage, in Kamuela Hi. This will be the 7th year we have made a mechanical Haunted House. This year we are making the tunnel using your plans. I can't tell you how excited everyone is. We have the rings cut and we are using a motor that was used to drive a robot they entered in "FIRST". What we don't understand is how the 2x3 hoop connector boards are connected. In your plans it shows the bolt inserted all the way down in the connector boards, and the tee nut also. Could you please elaborate?

A: The connection of the 2x3's to the end rings are pretty straight forward. About 2" in from the end of the 2x3 is a 1" hole drilled all the way through the board and is squared off (creating the "D" shape), as shown in the diagram on the web page, so that it can accommodate the tee nut. A hole is drilled lengthwise into the center of the 2x3 end, all the way to the hole created in the previous step.

The tee nut is inserted as shown in the diagram. A 1/4" x 3 1/2" bolt (with washer) is inserted through a hole in the ring, into the hold drilled in the end of the 2x3 and into the tee nut.

For the center ring, the end of one 2x3 is prepared exactly as above. The end of the 2x3 that goes on the opposite side of the ring needs to be prepared so that the 5 1/2" long bolt can be inserted and have enough room to get a socket wrench in to tighten the bolt.

To make the elongated "D" hole in that end of the 2x3, I drilled two 1" holes side-by-side and then used a chisel to combine them and square off the end as shown in the drawing. I then drilled a hold in the end of the 2x3 as above. In order to get the 5 1/2" bolt into this "D" hole and out the end of the 2x3, I made a slot in the 2x3, about 3 1/2' long, 5/8" wide and about 5/8" deep extending out from the "D" hole. I used a router with a straight cutting bit to create this slot, a chisel could be used if a router is not available.

- Q: What kind of lighting do you use in the tunnel?

A: The tunnel is lit using four 18" single tube black light fixtures, two mounted to each side of the bridge